

Mancal FC

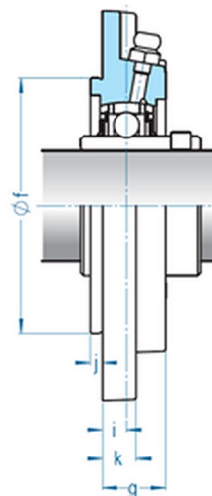
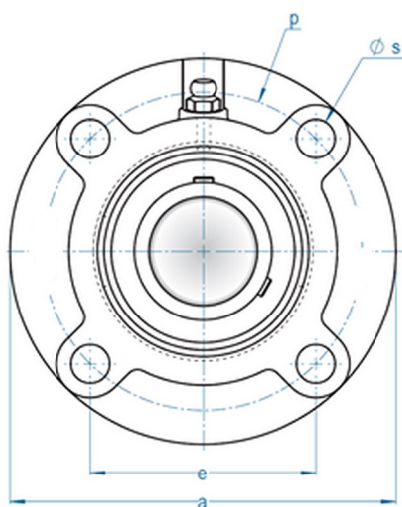

Modelo	Ø Eixo		Dimensões mm								
	Polegada	mm	a	p	e	i	s	j	k	g	f
FC-204	1/2		100	78	55,1	10	12	5	7	20	62
FC-204	5/8		100	78	55,1	10	12	5	7	20	62
FC-204	3/4		100	78	55,1	10	12	5	7	20	62
FC-204		20	100	78	55,1	10	12	5	7	20	62
FC-205	7/8		115	90	63,6	10	12	6	7	21	70
FC-205	15/16		115	90	63,6	10	12	6	7	21	70
FC-205		25	115	90	63,6	10	12	6	7	21	70
FC-205	1		115	90	63,6	10	12	6	7	21	70
FC-206	1.1/16		125	100	70,7	10	12	8	8	23	80
FC-206	1.1/8		125	100	70,7	10	12	8	8	23	80
FC-206		30	125	100	70,7	10	12	8	8	23	80
FC-206	1.3/16		125	100	70,7	10	12	8	8	23	80
FC-206	1.1/4		125	100	70,7	10	12	8	8	23	80
FC-207	1.1/4		135	110	77,8	11	14	8	9	26	90
FC-207	1.5/16		135	110	77,8	11	14	8	9	26	90
FC-207	1.3/8		135	110	77,8	11	14	8	9	26	90
FC-207		35	135	110	77,8	11	14	8	9	26	90
FC-207	1.7/16		135	110	77,8	11	14	8	9	26	90
FC-208	1.1/2		145	120	84,8	11	14	10	9	26	100
FC-208		40	145	120	84,8	11	14	10	9	26	100
FC-209	1.9/16		160	132	93,3	10	16	12	14	26	105
FC-209	1.5/8		160	132	93,3	10	16	12	14	26	105
FC-209	1.11/16		160	132	93,3	10	16	12	14	26	105
FC-209	1.3/4		160	132	93,3	10	16	12	14	26	105
FC-209		45	160	132	93,3	10	16	12	14	26	105
FC-210	1.13/16		165	138	97,6	10	16	12	14	28	110
FC-210	1.7/8		165	138	97,6	10	16	12	14	28	110
FC-210	1.15/16		165	138	97,6	10	16	12	14	28	110
FC-210		50	165	138	97,6	10	16	12	14	28	110
FC-210	2		165	138	97,6	10	16	12	14	28	110
FC-211	2		185	150	106,1	13	19	12	15	31	125
FC-211	2.1/8		185	150	106,1	13	19	12	15	31	125
FC-211		55	185	150	106,1	13	19	12	15	31	125
FC-211	2.3/16		185	150	106,1	13	19	12	15	31	125
FC-212	2.1/4		195	160	113,1	17	19	12	15	36	135
FC-212		60	195	160	113,1	17	19	12	15	36	135
FC-212	2.3/8		195	160	113,1	17	19	12	15	36	135
FC-212	2.7/16		195	160	113,1	17	19	12	15	36	135